

DIGEM 48 x 24 AK5

Digital Indicators for Grid and Mosaic Applications
Type A1125

- ❖ Display range $\pm 1\ 999$ digits, optionally $\pm 19\ 990$ digits
- ❖ Bright LED-Display with 8 mm character height
- ❖ Single standard mounting elements for all grid types
- ❖ Suitable for installation into all known grid configurations
- ❖ Extremely easy installation
- ❖ Power supply electronically separated from measurement circuit, 500 V test voltage

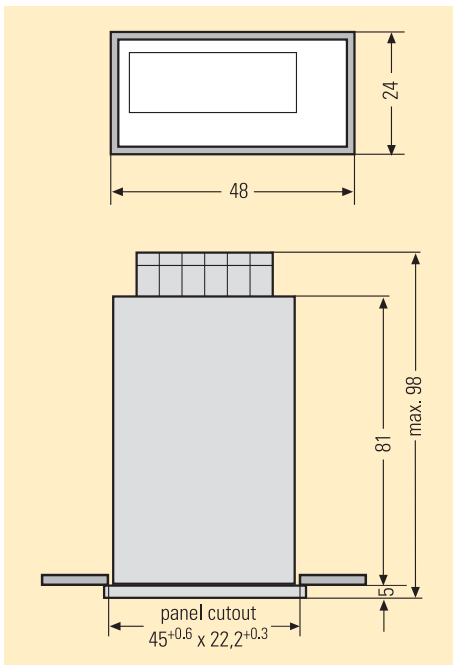

The DIGEM 48 x 24 AK5 panel meter is a 3½ digits display whose casing was especially developed for grid applications.

The included mounting elements allow for installation into all known 24 mm grid systems.

The instrument has a display range of $\pm 1\ 999$ digits, which can optionally be extended to $\pm 19\ 990$ digits by setting an additional digit hardwired to zero.

Decimal points are permanently set in the instrument, by means of solder bridges at the display, in accordance with the entries on the serial plate.

With measurements of 48 mm x 24 mm, this instrument can be fitted into practically any grid.

Installation in a control desk is possible because of the shallow installation depth of less than 100 mm.

With the use of coded jumpers and a potentiometer, it is possible to adjust the display range of the instrument.

The same method can be used to set the starting point of the measuring range.

This model is especially suited for display originating from measurement transducers.



Characteristic Values, DIGEM 48 x 24 AK5

Display

Type	7 Segment LED
Display Colour	red, optionally green
Character Height	approx. 8 mm
Display Range	$- 1\ 999 \dots 1\ 999$ option: $\pm 19\ 990$
Polarity	"-" is displayed automatically
Decimal Point	fixed
Overflow Display	"1..."

Measuring Ranges

Direct Voltage	± 200 mV to ± 50 V
Direct Current	± 200 μ A to ± 200 mA
Error Limits	$\pm (0,05\ \% + 2$ digits) [with option: $\pm 19\ 990$ $\pm (0,05\ \% + 20$ digits)]
Error Limits	< 100 ppm / °C
Offset Drift	$< 0,2$ digits / °C
Warm-up Time	approx. 1 min.

Power Supply

18 ... 36 V DC
24 V AC 50 / 60 Hz

A-D Conversion

Conversion Method	dual slope
Integration Time	approx. 100 ms
Measurements / second, typical	3: Response time for the overall instrument is greater depending upon the filter at the measuring input. It amounts to approx. 1 second.

Ambient Conditions

Operating Temperature	0 ... + 50 °C
Storage Temperature	- 20 ... + 70 °C
Relative Humidity	max. 85 %
Contamination Level	2
Surge Voltage Category	II

Casting

Protection	front panel: IP 50 rear panel: IP 20
Bezel	black matt; optionally grey, pebble grey or light grey
Installation Depth	max. 98 mm (without connector)
Weight	0.11 kg
Terminals	screw terminal blocks